

BUFFET

MANUAL DE MONTAGEM

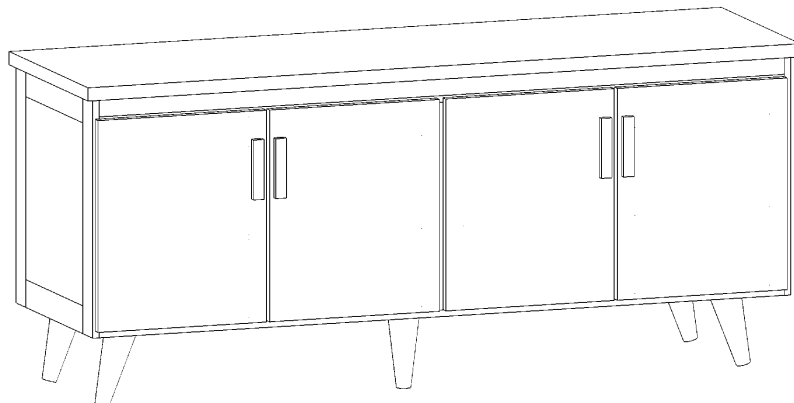

PESSOAS NECESSÁRIA
PARA MONTAGEM



PEÇAS

ACESSÓRIOS

CÓD.	DESCRIÇÃO	QUANT.	CÓD.	DESCRIÇÃO	QUANT.	QUANT.
01	BASE	1	A	DOBRADIÇA	26MM	8
02	PRATELHEIRA	2	B	CALÇO		8
03	DIVISÓRIA MENOR	1	C	PARAFUSO ESC. CAB	7X50	8
04	DIVISÓRIA MAIOR	1	D	PARAFUSO FLANG PH	3,5X30	8
05	LATERAL	2	E	PARAFUSO CH. PH	4,0X40	8
06	TAMPO	1	F	PARAFUSO CH. PH	3,5X12	60
07	RÉGUA SUPERIOR	1	G	CANTONEIRA	18X18	10
08	PÉS	5	H	SUPORTE PRATELHEIRA	8X55	8
09	FUNDO	4	I	CAVILHA	8X30	14
10	RÉGUA INFERIOR	1	J	PREGO	10X10	33
11	PORTAS	4	k	PORCA CILÍNDRICA		5
12	PUXADOR	4	L	PARAFUSO	1/4X60	5
			M	PERFIL H		2
			N	FIXADOR FUNDO		3

Passo 2:

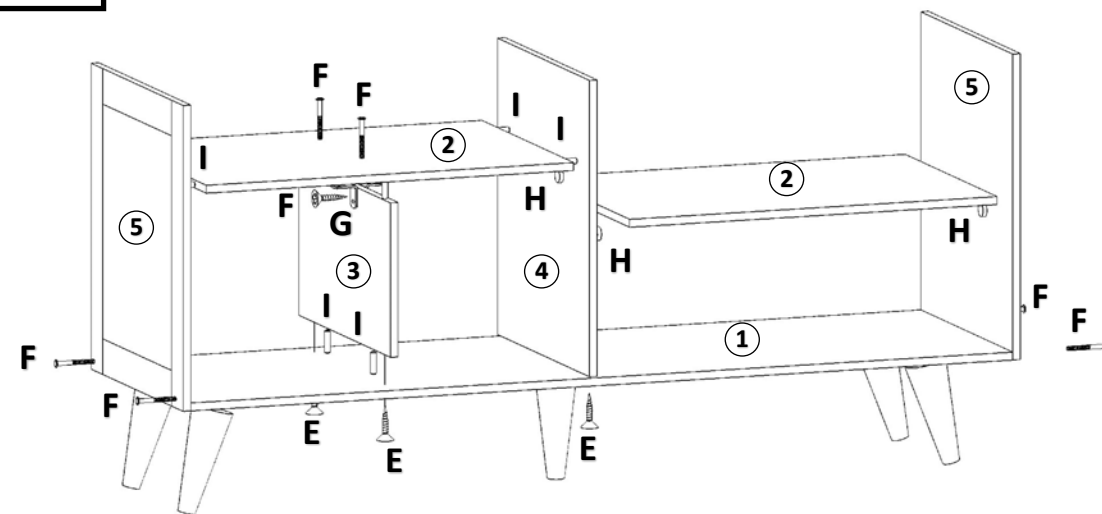

Passo 3:

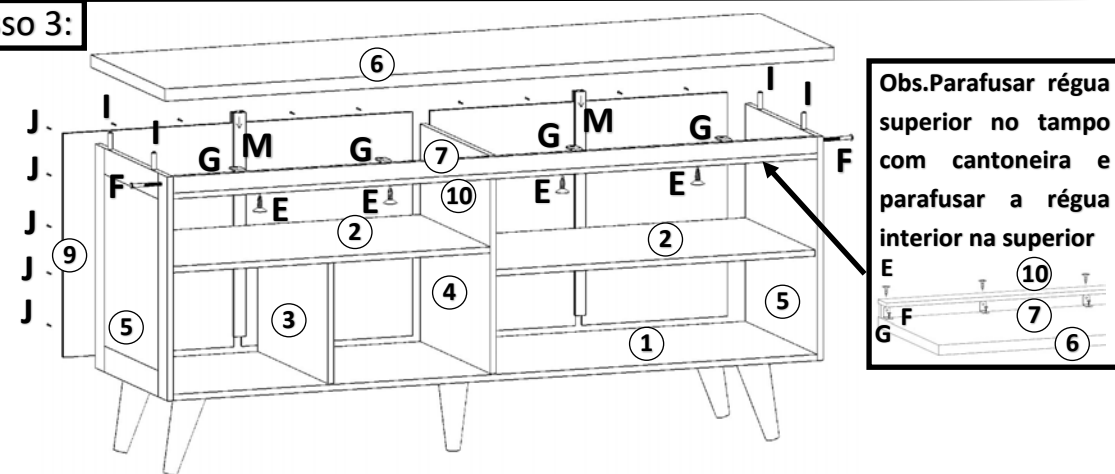

Obs. Parafusar régua superior no tampo com cantoneira e parafusar a régua interior na superior

Passo 1:

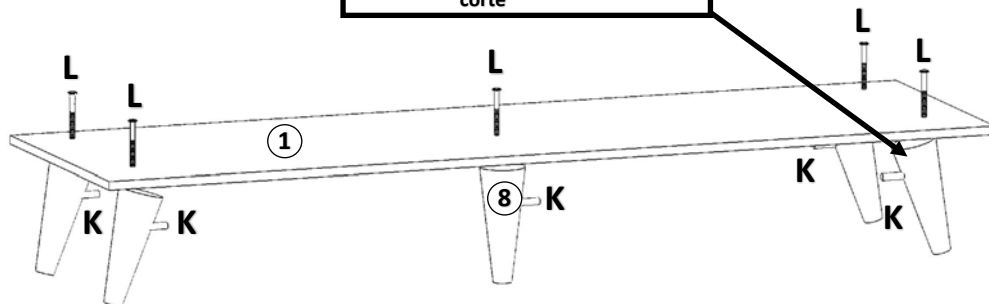
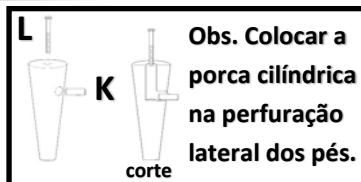

Passo 4:

